



SUBARU

Winger Subaru

2013 Starling Auckland Championship

Kohimarama Yacht Club

Kohimarama, Auckland

January 25-27 2014

(Incorporating Auckland Anniversary Regatta)

SAILING INSTRUCTIONS

1.0 RULES

- 1.1 The regatta will be governed by the rules as defined in *The Racing Rules of Sailing*.
- 1.2 The Yachting New Zealand Safety Regulations Part 1 shall apply.
- 1.3 Rule 26 is modified – see SI 11.3.

2.0 NOTICES TO COMPETITORS

Notices to competitors will be posted on the official notice board in the marquee located on the beach.

3.0 CHANGES TO SAILING INSTRUCTIONS

Any change to the sailing instructions will be posted before 0900 on the day it will take effect, except that any change to the schedule of races will be posted by 1800, or at end of protest time, whichever is earlier on the day before it will take effect.

4.0 SIGNALS MADE ASHORE

- 4.1 Signals made ashore will be displayed at the KYC flagpole.
- 4.2 Signals displayed with a Starling class flag will apply to the Starling class only.
- 4.3 When flag AP is displayed ashore, '1 minute' is replaced with 'not less than 30 minutes' in the race signal AP.
- 4.4 Flag D with a sound signal means: 'the warning signal will be made not less than 30 minutes after flag D is displayed.' Boats shall not go afloat until this signal is made.



SUBARU

5.0 SCHEDULE OF RACES

5.1

Day:	Date:	No of Races	Time of First Warning Signal:
Saturday	25th	3	1030
Sunday	26th	3	1030
Monday	27th	2	1030

5.2

One extra race per day may be sailed, provided that the event does not become more than one race ahead of schedule and the change is made according to instruction 3.

5.3

To alert boats that a race or sequence of races will begin soon, the orange starting line flag will be displayed with one sound at least five minutes before a warning signal is made.

5.4

For subsequent races on the same day the warning signal will be made as soon as possible after the finish of the preceding race but not less than 5 minutes after the finishing time of the last boat to finish.

5.5

On Monday 27th no warning signal will be made after 1330.

6.0 CLASS FLAGS

The Class flag will be: A red star on a white background

7.0 RACING AREAS

The race area will be in the waters of the Waitemata it off Kohimarama Yacht Club.

8.0 THE COURSES

8.1 The course diagrams show the courses, including the approximate angles between legs, the order in which marks are to be passed, and the side on which each mark is to be left.

8.2 No later than the warning signal, the race committee signal boat will display the course as black letters on a white background.

9.0 MARKS

9.1 Marks are described on the course diagram except that when there is a change of course the "New" mark will be an orange cylinder buoy.

9.2 A race committee boat signalling a change of a leg of the course is a mark as provided in instruction 12.2.



10.0 AREAS THAT ARE OBSTRUCTIONS

To the West is the West Bastion Reef structure marked by red and green beacons. To the East is East Bastion Reef marked by a red and green beacon with a cardinal mark to the East,

11.0 THE START

11.1 The starting line will be between a staff displaying an orange flag on the starting mark at the starboard end and the port-end starting mark/boat.

11.2 A boat starting later than 4 minutes after her starting signal will be scored Did Not Start without a hearing. This changes rules A4, and A5.

11.3 If flag U has been displayed as the preparatory signal, no part of a boat's hull, crew or equipment shall be in the triangle formed by the ends of the starting line and the first mark during the last minute before her starting signal. If a boat breaks this rule and is identified, she shall be disqualified without a hearing but not if the race is restarted or resailed or postponed or abandoned before the starting signal. This changes Rule 26 *Starting Races*. When flag U is used as the preparatory signal Rule 29.1 *Individual recall* does not apply

12.0 CHANGE OF THE NEXT LEG OF THE COURSE

12.1 To change the next leg of the course, the race committee will lay a new mark (or move the finishing line) and remove the original mark as soon as practicable. When in a subsequent change a new mark is replaced, it will be replaced by an original mark.

12.2 Except at a gate, boats shall pass between the race committee boat signalling the change of the next leg and the nearby mark, leaving the mark to port and the race committee boat to starboard. This changes rule 28, *Sailing The Course*.

13.0 THE FINISH

The finishing line will be between a staff displaying an orange flag on the finishing mark at the starboard end and the course side of the port-end finishing mark.

14.0 PENALTY SYSTEM

14.1 Appendix P, *Special Procedures For Rule 42*, will apply as changed by instruction 14.2

14.2 Rules P2.2, *Second Penalty*, and P2.3, *Third And Subsequent Penalties*, are deleted and rule P2.1, *First Penalty*, is amended to "When a boat is penalised under rule P1 her penalty shall be a Two-Turns Penalty under rule 44.2. If she fails to take it she shall be disqualified without a hearing."

15.0 TIME LIMITS AND TARGET TIMES

15.1 The target time is 55minutes and the time limit is 90 minutes

Failure to meet the target time will not be grounds for redress. This changes rule 62.1(a), *Redress*.

15.2 Boats failing to finish within 15 after the first boat sails the course and finishes will be scored Did Not Finish without a hearing. This changes Rules 35, *Time Limit And*



16.0 PROTESTS AND REQUESTS FOR REDRESS

- 16.1** Immediately after finishing a boat intending to protest shall, in addition to the requirements of rule 61.1(a), *Informing the Protestee*, inform the race committee at the finishing line of her intention to protest and the identity of the boat(s) protested against. The protesting boat must receive an acknowledgement from the race committee. This changes rule 61, *Protest Requirements*.
- 16.2** Rule 44.1 is changed to permit a boat that has broken a rule of Part 2 or rule 31 to take a penalty after racing but prior to any protest hearing. Her penalty shall be a scoring penalty as calculated in rule 44.3(c) equal to 40% of the number of entries in her fleet or 50% of the difference between her finishing position and the number of entries in her fleet, whichever is less
- 16.3** For protests where only a rule of Part 2, *When Boats Meet*, or Rule 31, *Touching A Mark*, is alleged to have been broken, an arbitration hearing will be offered prior to any formal hearing. Yachting New Zealand Regulation 4.5.5 will apply. (This changes Rule 44.1, *Taking A Penalty*). The scoring abbreviation for a penalty accepted at an arbitration hearing is ARB.
- 16.4** Protest forms are available at the race office, located at KYC. Protests and requests for redress or reopening shall be delivered there within the appropriate time limit.
- 16.5** The protest time limit is 90 minutes after the last boat has finished the last race of the day or the race committee signals no more racing today, whichever is later.
- 16.6** Notices will be posted no later than 15 minutes after the protest time limit to inform competitors of hearings in which they are parties or named as witnesses. Hearings will be held in the protest room, located at KYC.
- 16.7** Notices of protests by the race committee or protest committee will be posted to inform boats under rule 61.1(b), *Informing the Protestee*.
- 16.8** Breaches of instructions 18, 19, 21, and 22 will not be grounds for a protest by a boat. This changes rule 60.1(a), *Right to Protest; Right to Request Redress or Rule 69 Action*. Penalties for these breaches may be less than disqualification if the protest committee so decides.
- 16.9** On the last scheduled day of racing a request for reopening a hearing shall be delivered
- (a) within the protest time limit if the requesting party was informed of the decision on the previous day;
 - (b) no later than 30 minutes after the requesting party was informed of the decision on that day.
- This changes rule 66, *Reopening A Hearing*..
- 16.10** On the last scheduled day of racing a request for redress based on a protest committee decision shall be delivered no later than 30 minutes after the decision was posted. This changes rule 62.2.

17.0 SCORING

- 17.1** One race is required to be completed to constitute a series.



- 17.2** (a) When fewer than 5 races have been completed, a boat's series score will be the total of her race scores.
- (b) When from 5 to 8 races have been completed, a boat's series score will be the total of her race scores excluding her worst score.
- 17.3** For the Auckland Anniversary Regatta only, all races sailed on Monday 28th shall count. There will be no discards

18.0 SAFETY REGULATIONS

- 18.1** Competitors or their representatives shall check out each time they leave the shore to enter the course area, and shall check in each time they come ashore from the course.
- 18.2** A boat that retires from a race or returns to the launching area before she finished the last race of the day shall notify the race committee as soon as possible.

19.0 REPLACEMENT OF CREW OR EQUIPMENT

- 19.1** Substitution of competitors will not be allowed.
- 19.2** Substitution of damaged or lost equipment will not be allowed unless authorised by the race committee. Requests for substitution shall be made to the committee at the first reasonable opportunity.
- 19.3** Change of sail numbers will not be allowed without prior written approval of the Race Committee.

20.0 EQUIPMENT AND MEASUREMENT CHECKS

A boat or equipment may be inspected at any time for compliance with the class rules and sailing instructions. On the water, a boat can be instructed by a race committee equipment inspector or measurer to proceed immediately to a designated area for inspection.

21.0 SUPPORT BOATS

Except when requested to participate in rescue operations, team leaders, coaches, parents and other support personnel shall stay outside areas where boats are racing and are restricted to a 5 knot speed limit, from the time of the preparatory signal for the first start of a sequence of starts until all boats have finished or the race committee signals a postponement or abandonment of all races. The areas the boats are racing in is defined as the area inside the course and within 100 metres of any mark, lay line, starting line, finishing line or any area where any boat that is racing is sailing or may sail.

22.0 RADIO COMMUNICATION

Except in an emergency, a boat shall neither make radio transmissions while racing nor receive radio communications not available to all boats. This restriction also applies to mobile telephones.



23.0 PRIZES

There will be prizes for 1st, 2nd, 3rd, and 1st girl. In addition there will be prizes for the sailor who has travelled the furthest, the youngest and the oldest as well as spot prizes.

Prizes for the Auckland Anniversary Regatta will be awarded at a separate AAR ceremony on a date to be advised.

24.0 DISCLAIMER OF LIABILITY

Competitors participate in the regatta entirely at their own risk. See rule 4, *Decision to Race*. The organizing authority will not accept any liability for material damage or personal injury or death sustained in conjunction with or prior to, during, or after the regatta.



Course Illustration – Trapezoid with beat to finish - signal boat for start/finish

IW

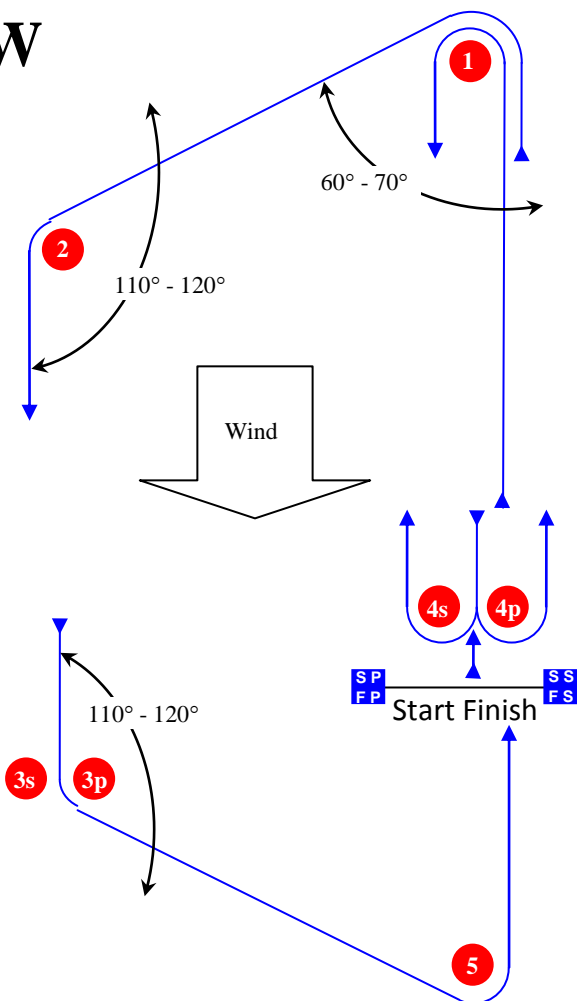

Course: Inner Trapezoid with beat to finish

Signal	Mark Rounding Order
IW1	Start – 1 – 2 – 3p – 5 – Finish
IW2	Start – 1 – 4s/4p – 1 – 2 – 3p – 5 – Finish
IW3	Start – 1 – 4s/4p – 1 – 4s/4p – 1 – 2 – 3p – 5 – Finish
IW4	Start – 1 – 4s/4p – 1 – 4s/4p – 1 – 4s/4p – 1 – 2 – 3p – 5 – Finish

OW

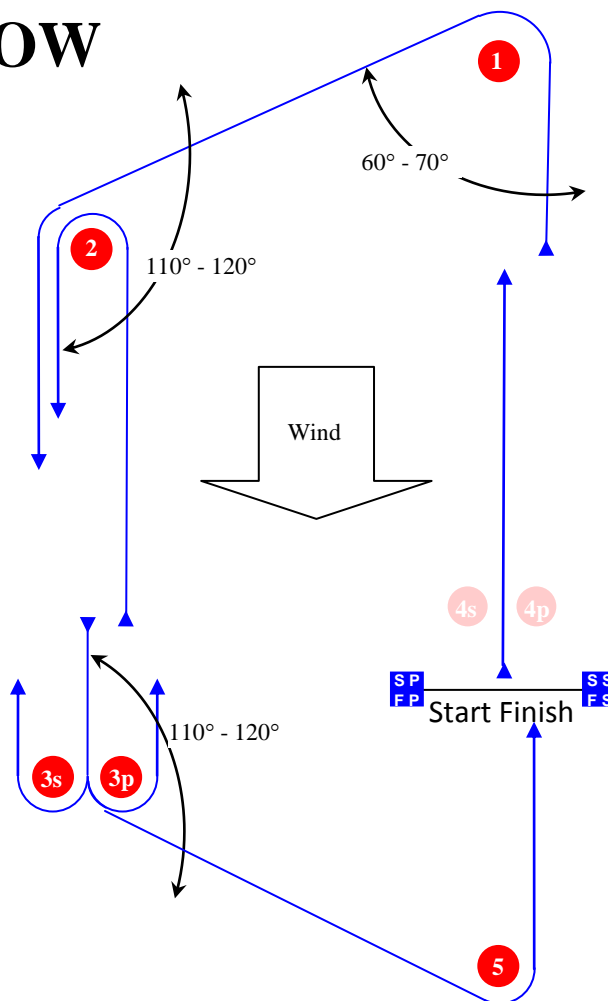

Course: Outer Trapezoid with beat to finish

Signal	Mark Rounding Order
OW2	Start – 1 – 2 – 3s/3p – 2 – 3p – 5 – Finish
OW3	Start – 1 – 2 – 3s/3p – 2 – 3s/3p – 2 – 3p – 5 – Finish
OW4	Start – 1 – 2 – 3s/3p – 2 – 3s/3p – 2 – 3s/3p – 2 – 3p – 5 – Finish

Mark	Description
1 2	Orange Cylinder
3s 3p	Orange Cylinder
4s 4p	Orange Cylinder
5	Orange Cylinder
SS Starting mark starboard end	Race Committee Signal boat
SP Starting mark port end	Orange Tear drop/Pin boat
FS Finishing mark starboard end	Race Committee Signal boat
FP Finishing mark port end	Orange Tear drop



Course Illustrations – Windward Leeward

L

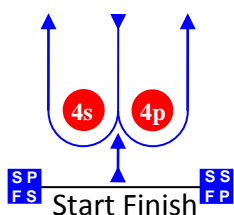
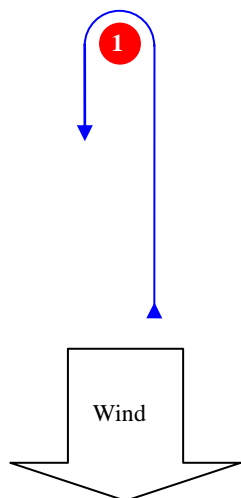

Course: Leeward finish

Signal	Mark Rounding Order
L2	Start – 1 – 4s/4p – 1 – Finish
L3	Start – 1 – 4s/4p – 1 – 4s/4p – 1 – Finish
L4	Start – 1 – 4s/4p – 1 – 4s/4p – 1 – 4s/4p – 1 – Finish

W

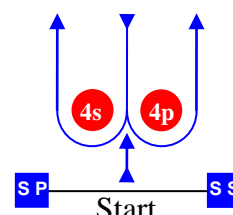
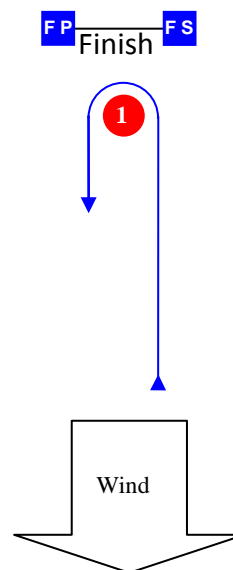

Course: Windward Finish

Signal	Mark Rounding Order
W2	Start – 1 – 4s/4p – Finish
W3	Start – 1 – 4s/4p – 1 – 4s/4p – Finish
W4	Start – 1 – 4s/4p – 1 – 4s/4p – 1 – 4s/4p – Finish

Mark	Description
1	Orange Cylinder
4s 4p	Orange Cylinder
SS Starting mark starboard end	Race Committee Signal boat
SP Starting mark port end	Orange Tear drop/pin boat
FS Finishing mark starboard end	Orange Tear drop*
FP Finishing mark port end	Race Committee signal boat*
	*These will be reversed if course W is used

