

# Course Illustration – Trapezoid: Opti Open, P Class, Starling, Laser, 29er, 420

## IW

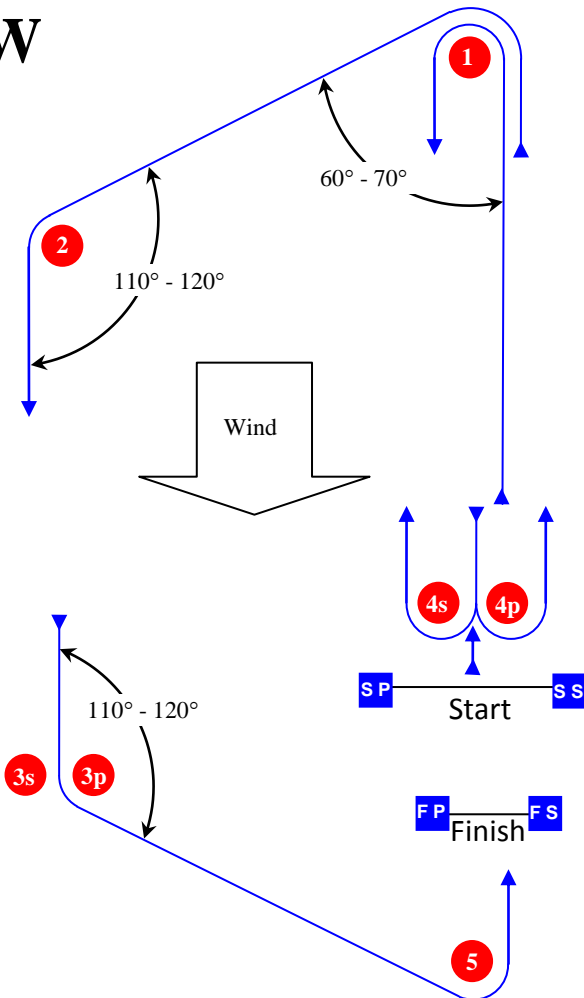

**Course: Inner Trapezoid with beat to finish**

Signal	Mark Rounding Order
<b>IW1</b>	Start – 1 – 2 – 3p – 5 – Finish
<b>IW2</b>	Start – 1 – 4s/4p – 1 – 2 – 3p – 5 – Finish
<b>IW3</b>	Start – 1 – 4s/4p – 1 – 4s/4p – 1 – 2 – 3p – 5 – Finish
<b>IW4</b>	

## OW

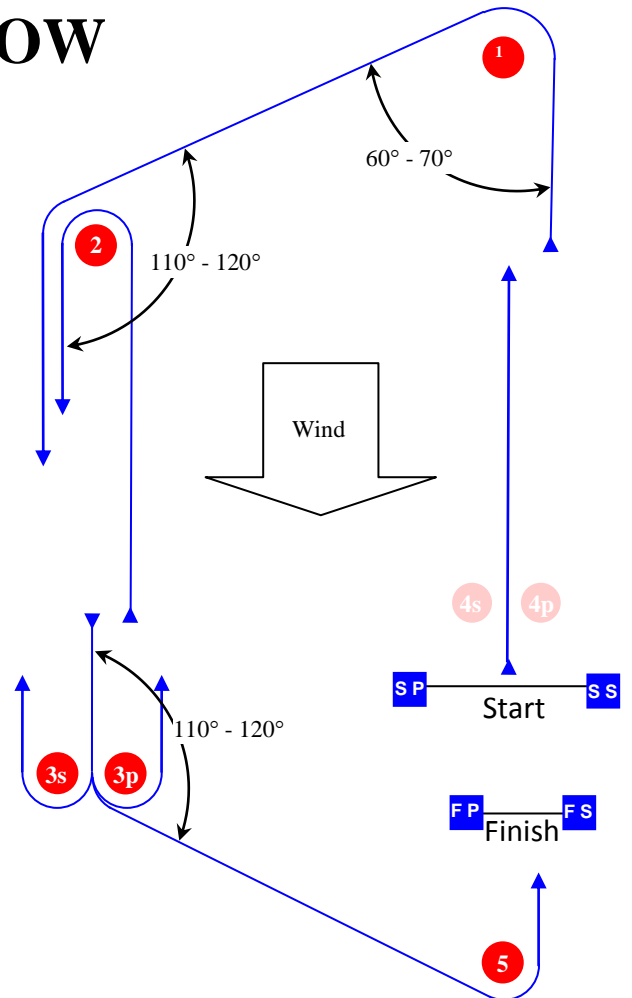

**Course: Outer Trapezoid with beat to finish**

Signal	Mark Rounding Order
<b>OW2</b>	Start – 1 – 2 – 3s/3p – 2 – 3p – 5 – Finish
<b>OW3</b>	Start – 1 – 2 – 3s/3p – 2 – 3s/3p – 2 – 3p – 5 – Finish
<b>OW4</b>	Start – 1 – 2 – 3s/3p – 2 – 3s/3p – 2 – 3s/3p – 2 – 3p – 5 – Finish

Mark	Description
1 2	Orange Cylinders
3s 3p	Orange Cylinders
4s 4p	Yellow Triangles
5	Orange Cylinder
SS Starting mark starboard end	Signal Boat
SP Starting mark port end	Orange Teardrop
FS Finishing mark starboard end	Finishing Boat
FP Finishing mark port end	Orange Teardrop